

NLED 30 Channel High Current LED Controller

This 30 channel LED controller from NLED is a versatile design with the ability to run powerful stand-alone sequences or can be controlled remotely using USB, DMX-512, or standard TTL serial. It is compatible with an external LED display that is used for displaying device states and for adjusting the device's configuration options such as the DMX address, selecting a stand-alone color sequence, or serial baud rate, among others. The software NLED Aurora Control is the easy-to-use software that can be used to create and upload custom color sequences to the controller, for it to run by itself without any data connections. It supports either 30 single color channels, 10 RGB channels, 7 RGB+W/U.V. channels, or a mixture of single/RGB/RGBW can be controlled. Either of the communication methods can be utilized to control the output channels. Each communication method supports 8-bit or 16-bit data, as the controller offers 12-bit(4096 levels) PWM resolution outputs. Best utilized with 12 volt LED strip(any configuration or color) or other high-wattage type LED configurations as the device supports up to 6A per output channel.

Features:

- 30 Output Channels, up to 8A per channel. 2.5A per if all channels are on at once, 75A max for controller.
- Small size, 4.5" x 3.3" x 0.5" or 1" tall
- USB(Emulated Serial Port) Communication via NLED Aurora commands. Easy to interface through many languages to create custom software and for special usages. Control the outputs with 8-bit or 16-bit data.
- DMX-512 With 7 DMX Reception Modes(see page 4 & 5), including 8-bit or 16-bit reception types.
- TTL or RS-485 Serial Reception at a selectable baud rate, communicate with Arduino's, FTDI, and more.
- External 3-Digit LED Display, on a ribbon cable for easy use and case mounting. Blue LED display.
- Hardware and Firmware supports single color LEDs(ex. all blue), RGB or RGB+W/U.V. configurations.
- NLED Aurora Control Software compatibility, connection via USB Type B (same as a printer)
Create and Upload(save) Custom Stand-Alone Color Sequences to the Controller From a Computer.
- Fast PWM Frequency rate at 1.5KHz with 8-bit or 12-bit PWM Resolution(depends on usage)
- DMX Master Capability, optional DMX transmission during stand-alone usage, sync multiple devices or control other DMX devices of any type. Full packet and Partial packet option.
- All user configurations and settings are saved to the device and restored when powered up.
- Serviceable Design, in case of any damage caused by accidents. Includes a Full 3 Year Warranty and Satisfaction Guarantee

Specification:

Input Voltage	5v*, 7v - 24v
Logic Current Draw	< 250mA
Output	30 Channels, Current Sink
Max Current Per Output	8 Amps
Max Current Overall	75 Amps
PWM Frequency	1.5kHz
Connectors	Terminals**
Connector Spacing	0.2"(5.08mm)
Main PCB Dimension	4.5" x 3.3" x 0.5"
LED Display Dimension	1.5" x 1.5"

*5 volt input will work, but DMX(RS-485) may not function correctly without a simple hardware tweak.

**Screw-down, pluggable, screw down, and solder pad types are available

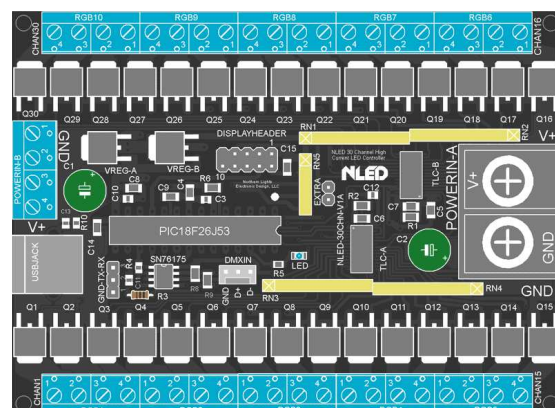

Pinout detailed on Page 7

Button Use and Options Menu Navigation

Pressing and Holding both buttons will open the device menu which allows the device settings and features to be adjusted. When both buttons are pressed, and held, the display will indicate by animating “. . .” Once the menu is open(Enu) use SW1(left) to cycle through the options and SW2(right) to select an option. Changes takes a few seconds to save.

Fig. 2a

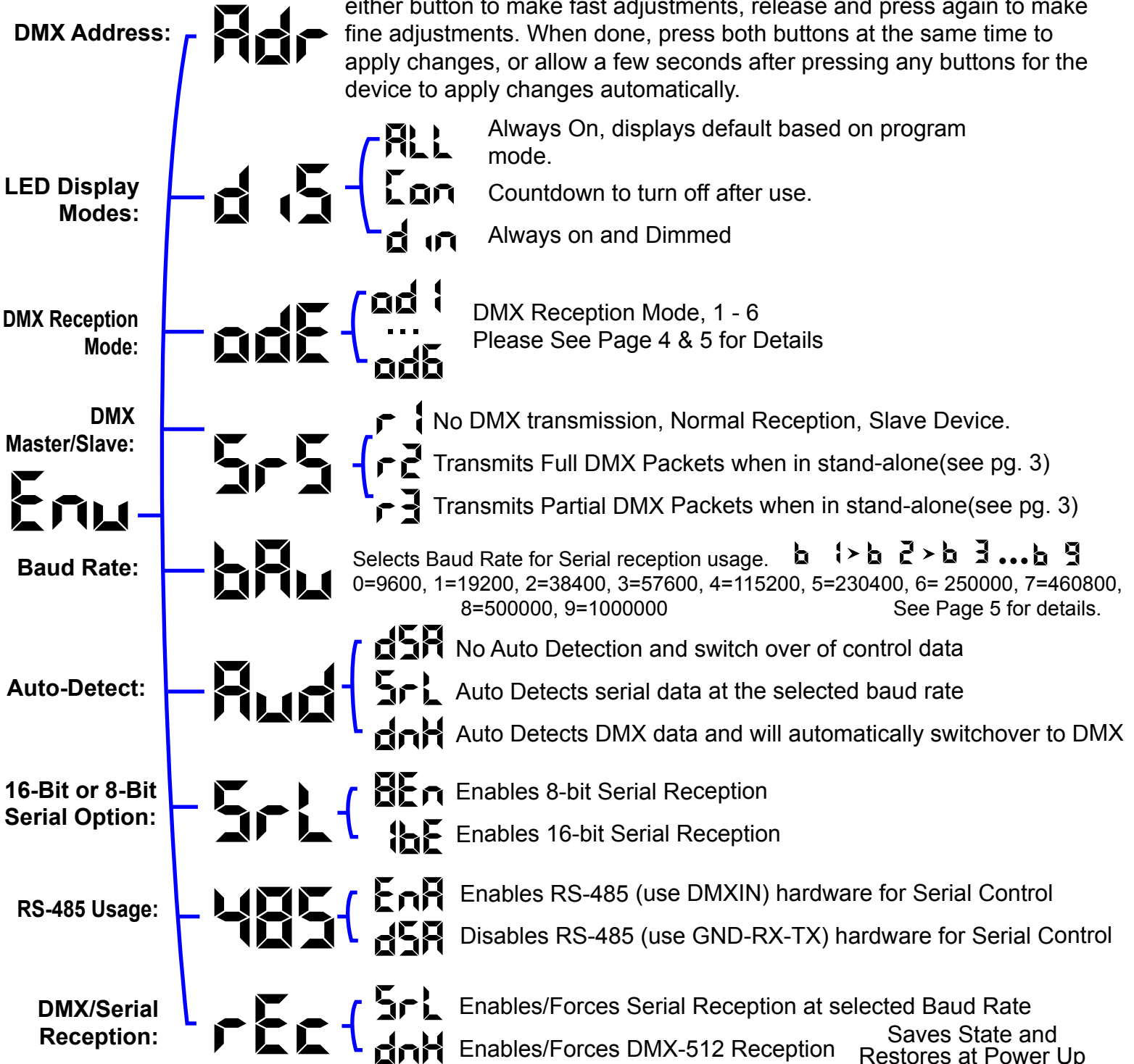

Firmware Updates Using The Bootloader

This device includes a bootloader feature. It allows the firmware on the device to be updated using a USB cable and a small computer program. The bootloader entry method for this is to: with the device powered off, while holding down SW1 on the external LED display or after making the jump connection in Figure 3a, power up the device. Wait a second or two. The device's notification LED should be full on if it entered bootloader mode and will blink steadily if in bootloader mode and successfully communicating with the host computer. When the software is started (or if it is already started) it will automatically connect to the device if one is found.

After the device is connected, please follow the instructions found at www.NLEDshop.com/bootloader. That is also where the software download links can be found.

Firmware updates are programmed special protection code that prevents other devices from being programmed with the update firmware images. And non-NLED firmwares from being programmed onto the devices. If a firmware image is loaded onto a microcontroller without the special protection code it will respond to commands and USB will work, but the outputs will be off. Contact Us for help restoring your device to original condition if your microcontroller was damaged, erased, 'bricked', or otherwise not working correctly.

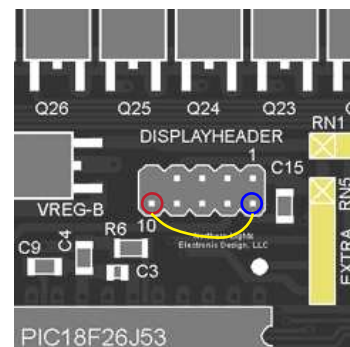



Jump the blue circled pin to the red one to enter bootloader mode without a external LED display.

Fig. 3a

Auto-Detection, DMX or Serial

One of the configuration options allows the device to detect valid serial data or DMX signal and automatically switch from stand-alone sequences to the selected data signal type. For DMX it will take a few packets of good data for the device to validate the signal and then switch over. Serial auto detection is similar, it must detect several packets of serial data at the correct baud rate for it to validate the signal and switch over from stand-alone sequences. The configuration can be changed in NLED Aurora Control

DMX Master Transmission Modes

-  No Master DMX Transmission, device receives normally. As Slave when enabled.
-  Transmits full DMX Universe when in Stand-Alone Mode, transmits the repeating values of the output channels to all DMX channels. 1-30, 31-60 etc up to 512
-  Transmits a partial DMX Universe(256 channels) when in Stand-Alone mode. Same as above but output channel values are repeated 1-30,31-60 etc up to channel 256.

Through software 8-bit or 16-bit DMX master transmission can be selected. 16-bit mode transmits MSB first, then LSB. Not compatible with all DMX devices, check device specifications for details.

Note: If a DMX Transmitter is attached to the device(s) it will load the line and Master transmission will not work until the other transmitter is removed from the circuit, and once a device is Master transmitting and DMX transmission is restored, all devices in the universe will act erratically for a few seconds.

DMX-512 Usage

The device supports multiple DMX-512 reception modes, a reception mode can be selected through the software or external LED display. It can also be a setup as a DMX Master device(detailed on previous page), which will broadcast a DMX universe when running stand-alone color sequences. The data transmitted will be the same as the device's *Output Channel* values. So two or more of the same device could be daisy chained together and would be synchronized.

DMX Reception Modes

30 Channel Mode, 8-bit: Standard Direct Control(od1)

<u>Channel</u>	<u>Value</u>	<u>Description</u>
1	0 - 255	Output Channel 1, 0 is Off, 255 is Maximum Value
.....		
30	0 - 255	Output Channel 30, 0 is Off, 255 is Maximum Value

31 Channel Mode, 8-bit: Standard Direct Control with Intesity(od2)

<u>Channel</u>	<u>Value</u>	<u>Description</u>
1	0 - 255	Output 1, 0 is Off, 255 is Maximum Value
.....	0 - 255	
30	0 - 255	Output 30, 0 is Off, 255 is Maximum Value
31	0 - 255	Intesity. 0 is 0%, 255 is 100% Maximum Intesity on all channels

60 Channel Mode, 16-bit: 16-Bit Direct Control (od3)

<u>Channel</u>	<u>Value</u>	<u>Description</u>
1	0 - 255	MSB of Output 1
2	0 - 255	LSB of Output 1
.....	0 - 255	Etc.
59	0 - 255	MSB of Output 30
60	0 - 255	LSB of Output 30

Note: The maximum PWM resolution is 12-bits(4096 brightness levels), so the 4 LSBs are unused

62 Channel Mode, 16-bit: 16-Bit Direct Control With 16-Bit Intensity (od4)

<u>Channel</u>	<u>Value</u>	<u>Description</u>
1	0 - 255	MSB of Output 1
2	0 - 255	LSB of Output 1
.....	0 - 255	Etc.
59	0 - 255	MSB of Output 30
60	0 - 255	LSB of Output 30
61	0 - 255	Intensity Value MSB 0 is 0%, 65,535 is 100% Maximum
62	0 - 255	Intensity Value LSB Intensity applied to all channels.

Note: The maximum PWM resolution is 12-bits(4096 brightness levels), so the 4 LSBs are unused

Need something different? Custom? Contact Support@NLEDshop.com for Help

DMX Reception Modes(Continued)

3 Channel Mode: Standard RGB Compatibility(od5)

<u>Channel</u>	<u>Value</u>	<u>Description</u>
1	0 - 255	All Red Channels, 0 is Off, 255 is Maximum
2	0 - 255	All Green Channels, 0 is Off, 255 is Maximum
3	0 - 255	All Blue Channels, 0 is Off, 255 is Maximum

These 2 DMX Reception Modes are used for control of the stand-alone color sequences. There must be Sequences loaded onto the controller, either the stock ones or user created ones that were created and Indexed with the NLED Aurora Control Software.

3 Channel Mode: Basic Sequence Control(od6)

<u>Channel</u>	<u>Function</u>	<u>Value</u>	<u>Description</u>
1	Sequence #	0 - 32	0 Blanks the All Outputs, 1-32 maps to indexed sequences
2	Speed	0 - 255	0 is Pause, 1 - 255 is the speed used for sequence
3	Position/Fade	0 - 255	If Speed is greater than 1, usage is ignored. See Note 1.

33 Channel Mode: Sequence Control with 30 Channel Control(od7)

<u>Channel</u>	<u>Function</u>	<u>Value</u>	<u>Description</u>
1	Sequence #	0 - 32	0 control using channels 4 - 33, 1-32 maps to sequences
2	Speed	0 - 255	0 is Pause, 1 - 255 is the speed used for sequence
3	Position/Fade	0 - 255	If Speed is greater than 1, usage is ignored. See Note 1.
4		0 - 255	Output Channel 1
5		0 - 255	Output Channel 2
...		0 - 255
32		0 - 255	Output Channel 29
33		0 - 255	Output Channel 30

Note 1: Position/Fade Control: If the Speed is 0, it allows the position of Instant Sequences to be set by the Positon value. As calculated: $(\text{Position} / 255) \times \text{Amount of Data Frames}$. For Fade and Gradient Sequences, it allows the Sequence to run normally for Position value amount of times, which for 8-bit sequences, a value of 255 will run all output channels 1 frame. For Fades and Gradient sequences, the Positon value used is the difference between the previous Position value and the current Position value.

Need something different? Custom? Contact Support@NLEDshop.com for Help

Serial Reception Usage

Serial reception can directly control the device's outputs using a common serial transmission device. Such as a standard COM port with level translation, an FTDI adapter, Arduino, PIC UART, wireless XBee, or similar. Data is received in packets of 30 bytes for 8-bit reception mode and 60 bytes, MSB first, for 16-bit mode. There is a maximum of 5mS between bytes and a minimum of 5mS between packets, to allow the data to latch. A delay between received data bytes of more than 5mS will reset the buffer pointer, framing the data. Partial packets will latch after the 5mS delay, or latching will occur immediately after receiving the last(30th or 60th) byte. 8-bit or 16-bit reception modes are selected through the configurations, which can be accessed through the software, USB commands, or through the external LED display.

Serial Reception can be enabled through the NLED Aurora Control Software by adding it to an index, or by selecting through the external LED display. Or in the software, on the Hardware Tab, select the Auto-Detect Serial option to automatically enter Serial Reception when valid data is received, the device can take several packets to detect and validate the data before starting reception. The stock baud rate is 19,200, but the user can set the utilized baud rate using the software through the hardware tab by selecting the desired baud rate from the drop down menu. Or by selecting ID through the external LED display. The byte formatting is the standard 8-N-1(8-bits, no parity, 1 stop bit)

For Serial Reception to function the RS-485 hardware must be configured. RS-485 is a differential transmission method, that DMX-512 utilizes. The user can select through the software or external LED display to utilize the RS-485 hardware for Serial Reception(transmitting device must be RS-485 as well) on the DMXIN header or to disable usage and utilize the RX-TX-GND header for direct TTL (Low=0v, High=5v, 3.3v levels will work as well) control.

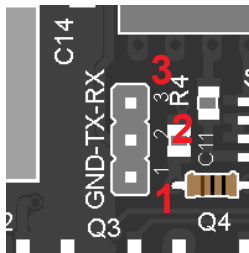

Fig. 3c

RX-TX-GND Header Connection

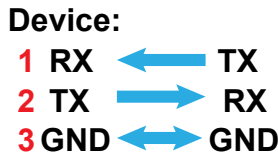

Fig. 6b

ID#	Actual Device Baud	Closest Common Baud Rate	Error %
0	9,615	9,600	0.16%
1	19,230	19,200	0.16%
2	38,461	38,400	0.16%
3	57,142	57,600	0.64%
4	117,647	115,200	-0.79%
5	222,222	230,400	2.12%*
6	250,000		
7	444,444	460,800	-3.55%*
8	500,000		
9	1,000,000	921,600	8.51%

Fig. 6a

8-N-1

*Note: Percentage of error is within usable limits. And won't affect usage.

USB Live Control & USB Commands

Live control over USB allows data sent from a computer to control the Output Channel intensities. This device when connected over USB is an Emulated Serial Port or VCP. This allows computers to see the device as a regular serial port. Many languages provide communication with serial devices, which allows many options for a user to create custom software to control the Output Channels over USB. Live control is started through NLED Aurora Control commands. There is data byte option to enable 8-bit or 16-bit reception over USB. 16-bit allows 65,536 intensity levels, although the device converts it down to 12-bit(4096).

NLED Aurora Control commands are compatible with all devices that are compatible with the software. The commands can be executed from any software or program that can connect to the device. Communication involves a simple byte exchange and acknowledge, then the command byte and 4 data bytes are sent to the device. See software documentation for command details and usages.

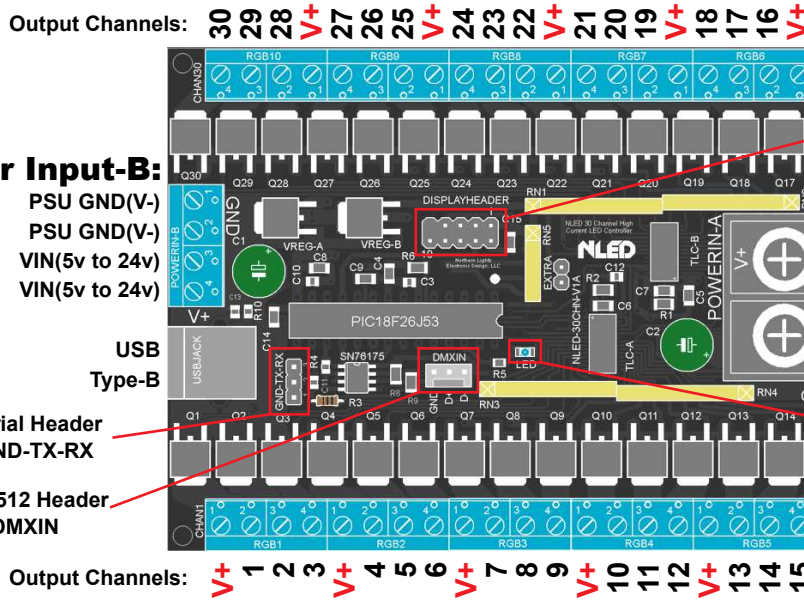

Fig. 7a

For or High Power Applications(30A+), power should be supplied to both Power Inputs (one on each end)

LEDs and Configuration

The controller outputs are current sinking, meaning the cathode of the LED(s) or LED string is connected to the controller's *Output Channels* and the anode(s) are connected directly to the positive supply voltage. Either using one of the V+ terminal positions or directly to the power supply. This device does not control current, and the LED or LED string must use a resistor(s) or other method to control the current flowing into the *Output Channel*. All V+ terminals are tied together and tied to VIN, the source voltage.

Many configurations of LEDs can be controlled. Such as standard 12 volt LED strip or 12 volt RGB(W) LED strip(common anode), series/parallel or single high wattage LEDs (1w, 3w, 5w, 10w, 20w, +more up to max specification) or series/parallel or single 10mm, 5mm LEDs with a current limiting resistors. And multi color LEDs with common anodes

Need help or have questions? Contact Support@NLEDshop.com for Help

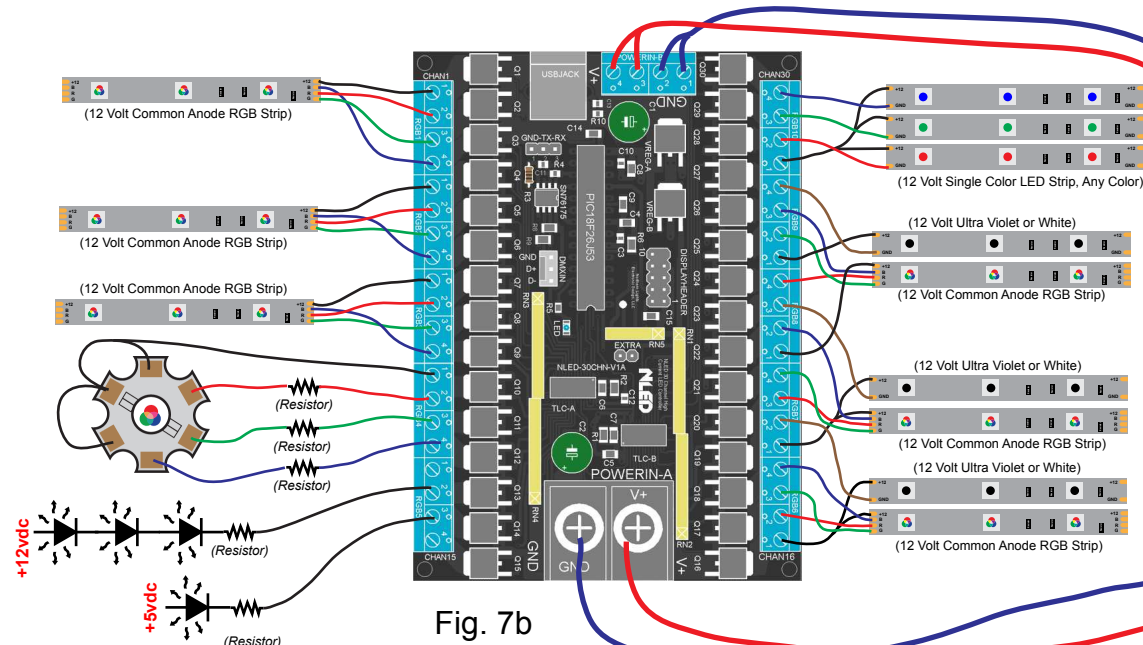

For or High Power Applications(30A+), power should be supplied to both Power Inputs (one on each end) Otherwise use Power Input-A

Power Supply wire should be of proper gauge and rating

PSU GND Power Supply 7VDC to 24VDC Amperage Varies

Fig. 7b

Power Considerations

The controller is rated for a maximum of 75 Amps, in order to achieve that properly, power should be supplied directly from the PSU to BOTH Power Input positions. Power Input-A is rated for 45A and Power Input-B has 2 positions for each for GND and V+, each rated for 17.5A(technically 80A could be achieved) As the power draw reaches the limit, the controller should be allotted additional airflow.

Each Output Channel is rated for 8A each, but on average each output should be limited to 2.5A(30x 2.5A = 75A) Each Output Channel can support up to 60 volts, but the controller's voltage regulators limit input power to the controller to 24 volts. Contact for assistance if you need to utilize more than 24 volts for your LED configuration.

If utilizing 12 volt to 24 volt input voltage, it is advised to set the external LED display to countdown, dim, or countdown+dim mode, as the voltage regulator may not be able to supply power to the LED display safely.

Dimensions and Mounting Considerations

Width: 4.5" (114mm)

Height:
3.3" (84mm)

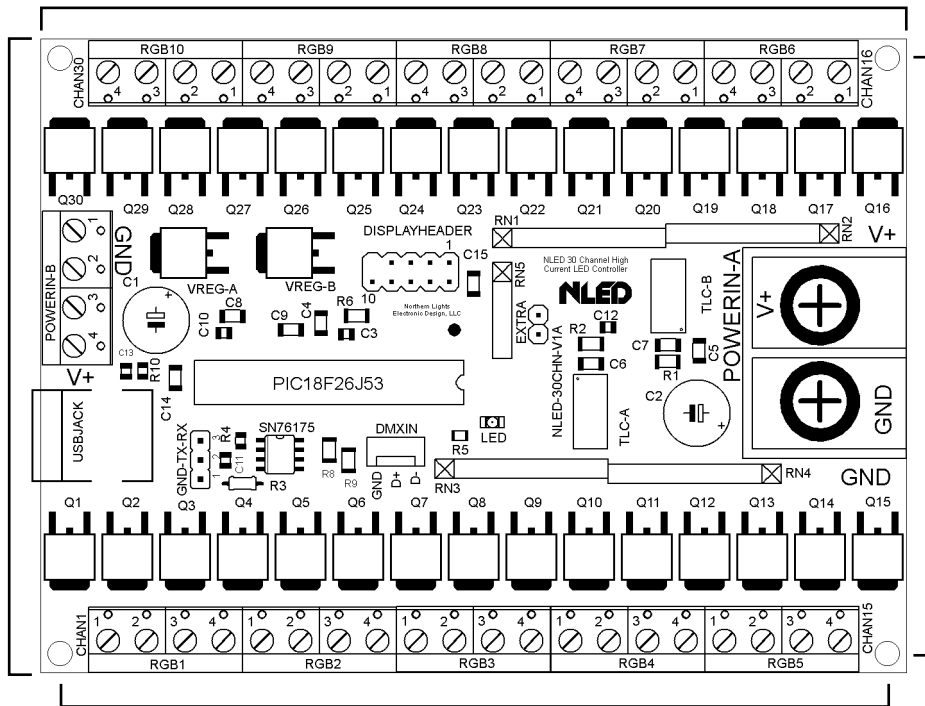

Mounting Holes
Height:
3.1" (79mm)

Mounting Holes Width
4.3" (109mm)

Fig. 8a

Mounting Notes:

- Do not allow bottom of PCB to touch anything conductive.
- Do not allow foreign material to fall onto or accumulate on the device.
- The device should be kept dry and clean. If the device becomes wet or dirty, do not use until it is cleaned and dried. Contact Us for assistance.
- Allow the device to have proper airflow, do not enclose without venting. Required airflow is dependent on how much current the controller is drawing. Higher power applications require more airflow.

NLED Quasar Model

The NLED 30 High Current LED Controller is also available in turnkey controller with case. The NLED Quasar controller. It offers all the available features with pluggable terminal blocks, a fully enclosed decorative enclosure, with access to all the data connections(excluding TX-RX-GND), DMX-512 is accessible via a Tiny XLR(mini, Rean RT3MPR). The Tiny XLR jack requires a custom cable designed for use with the NLED Quasar which converts male and female 3-pin XLRs into the required Tiny XLR.

Dimensions and Mounting Considerations

Total Dimensions:

5"/127mm x 4.5"/114mm x 1.25"/32mm Tall

Material: 1/8" Acrylic

Leave about 1" all around the controller so the data and output connections can be made.

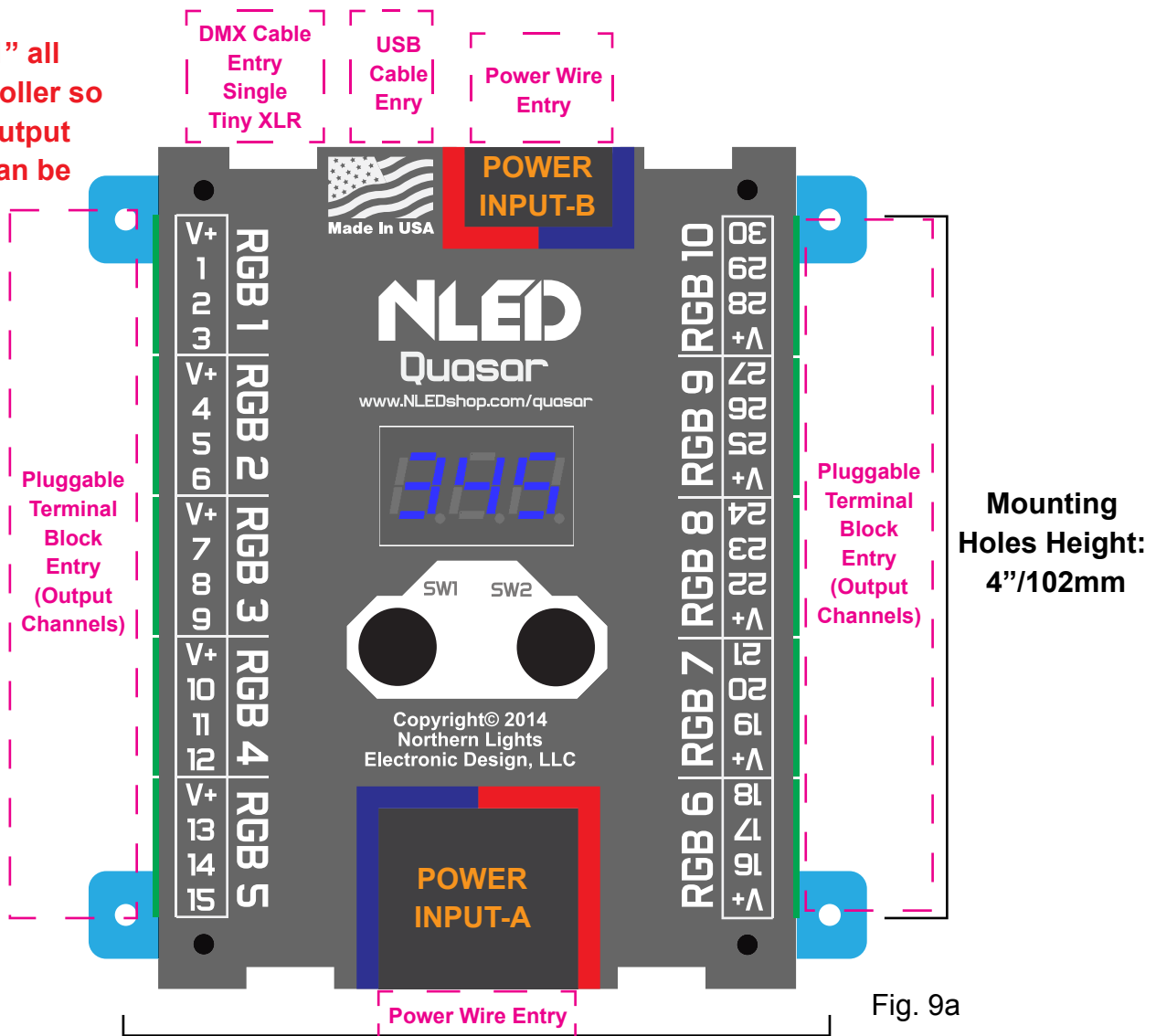

Fig. 9a

Note:

The enclosure is not water or weather proofed. Care must be take when choosing a mounting location. The enclosure has venting slots, they can not be obstructed or sealed.

Common Issues and Troubleshooting

Please Contact Support@NLEDshop.com with any Questions, Comments, or Bug Reports.

Most issues can be resolved by power off the device, waiting a few seconds, and powering it back up.

Problem: Device with connected LEDs does not produce any light.

First ensure the LEDs are properly powered and wired to the controller and power source. Try to cycle through the Sequences or modes using the button or External LED display.

Problem: Device with connected LEDs is full on, or all white.

Potential microcontroller issue, attempt to flash the firmware using the bootloader (see page 3) or contact support for assistance.

Problem: Device appears to be “bricked”, unresponsive to user inputs and/or communication(USB etc)

Attempt to upload a new firmware image via the Bootloader, see page 4 for details.

Problem: USB connection is not being established.

Check to make sure the USB cable is plugged and seated correctly, then power up the device. Check for connection via NLED Control or your operating systems device manager, it should be listed as a COM port. All major operating systems should not require a driver. So the device should plug and play.

Problem: Outputs flicker or have inconsistent light output.

Power supply may not be properly rated or has poor load/line regulation.

Have Any Ideas for Future Updates:

Northern Lights Electronic Design, LLC is constantly looking to make our products better and improve upon our designs. If you have any ideas for future products, updates to current products, or features that you would find useful, please Contact Us at Sales@NLEDshop.com. There is a good chance you can receive coupons or free items for your help.